

# Catalyst Reactor System

## BEL-REA



### [Features]

- BEL-REA is a catalyst reaction measurement instrument developed by BEL Japan, Inc.
- Compact, accurate, user friendly, and values on customization
- Easy operation and small space occupation
- Laboratory type instrument, which does not choose a place to put
- The main components are; source material supplier (3 gas supplying systems and 1 liquid supplying system), vaporizer, and reactor.

## [Specifications]

### Flow diagram

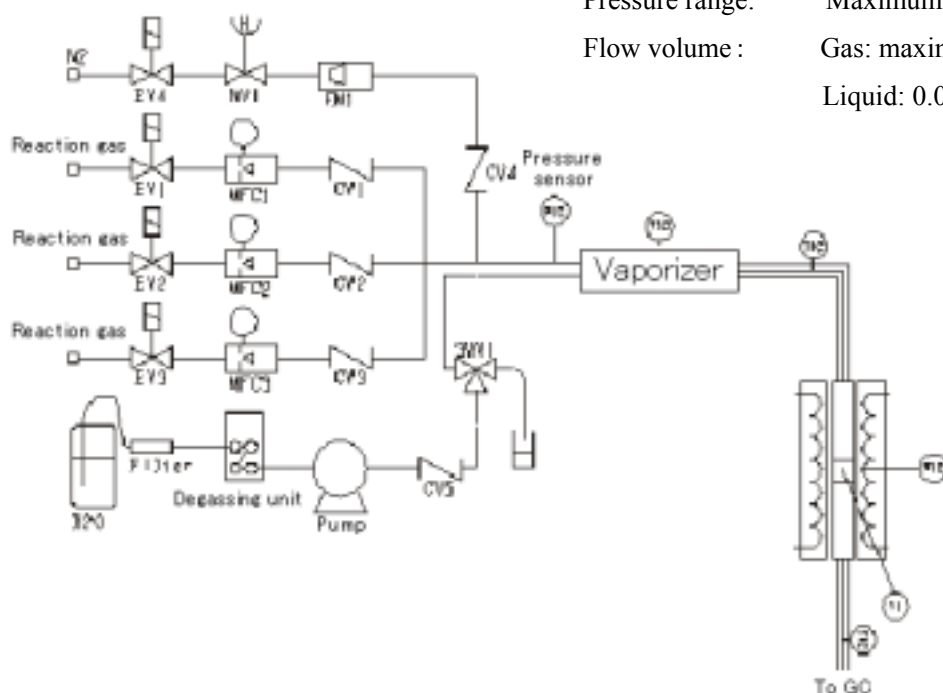

Temperature range: 500°C (regular use)

1000 °C (Maximum)

Pressure range: Maximum 0.98MPa

Flow volume : Gas: maximum 500 ml/min

Liquid: 0.01 ~ 9.0 ml/min

### <Specifications of each component>

Electric furnace	
Hear insulator	Fine ceramics
Heater	PyroMax
Operating temperature range	50 °C ~ 1000 °C
Soaking area	At 800°C, 200mm+/-2 °C of the center zone
Configuration	Twofold method, including safety cover
Dimension of inside furnace	30Φ x 300mm
Electric capacity	500W
Reactor tube	
Shape	Straight type Including internal temperature measurement accepting tube and catalyst tray function
Length	12.7 x 350mm
Thickness	1 mm
Material	sus316
Display	
Pressure display	1
Internal temperature display	1
Gas flow volume display	3
Analyzer	Packed type general-purpose gas chromatograph Specifications can be determined after the discussion meeting with our engineers

<Specifications of each component>

Vaporizer Material Internal filling material Heating method	sus316 High purity ceramic beads Direct heating by Heath heater
For the safety	Shut down the instrument if there is a certain change of temperature or pressure
Physics Main body Weight	W800mm x D600mm x H600mm (excluding the analyzer) Approximately 50kg
Electric capacity	AC100V1Φ15A
Control system Gas flow volume control Range of set flow volume  Liquid flow volume control  Withstand pressure Range of flow volume Temperature control Setting and display A: Electric furnace Display Display accuracy Control method  Sampling method Power adjustment B: Line heater Display Display accuracy Control method Sampling period Power adjustment	Mass flow controller Gas 1 10 ~ 500 SCCM Gas 2 0.6 ~ 30 SCCM Gas 3 0.04 ~ 2 SCCM Double plunger method liquid sending pump Adopted 5-phase stepping motor 10Mpa 0.01 ~ 9.9 ml/min Upper part of the panel 7-segment LED, 4 digits +/- (0.25%fs + 1 digit) Including auto tuning function, PID continuous control method 0.25 second SCR method  7 segments, 4 digits +/- (0.5%fs + 1 digit) Including auto tuning function, PID on/off control method 0.5 second SSR method

**BEL Japan, Inc.**



Main Office: 1-9-1, Haradanaka, Toyonaka-shi, Osaka 561-0807 JAPAN  
 Phone: +81-(0)6-6841-2161 FAX: +81-(0)6-6841-2767  
 E-mail: international@nippon-bel.co.jp  
 URL: <http://www.nippon-bel.co.jp>